



IMS
Select

Gas Assist Nozzles and Accessories

Save money and improve quality at the same time

Gas-assist injection molding results in stronger parts with better uniformity of cross section, while reducing injection pressure. It is ideal for long or irregularly-shaped, hollow parts.

We offer a complete line of accessories for nitrogen gas-assist molding. Included are add-on gas ports and nozzle bodies with gas ports, shutoffs and valves, check valves and in-mold gas injection pins. These components are compatible with all gas assist molding systems.

- Rotary Resin Shutoff Valve prevents nitrogen from entering the barrel during the nitrogen injection phase. This valve is hydraulically actuated for positive shutoff. Use it in conjunction with removable tip style nozzle bodies having a gas injection port.

- Add-On, Self-Actuating Shutoff with Gas Port also prevents nitrogen from entering the barrel during the nitrogen injection phase. The nitrogen gas pressure actuates an internal spring to effect shutoff. This nozzle includes a gas-assist port.
- Add-On Gas Port converts with any standard nozzle to a gas-assist nozzle.
- Cone (needle) check valve prevents plastic from backing up and plugging the nitrogen injection line. It's easy to install and made of stainless steel.
- Spring-loaded check valve also prevents plastic from backing up and plugging the nitrogen line. This type allows increased nitrogen gas flow while reducing nitrogen injection pressures.
- In-Mold gas pins permit injection of nitrogen gas directly into the mold rather than the nozzle.

NOTE: In order for standard nozzles with gas port and add-on, self-actuating shutoff with gas port to reach recessed sprues, die clearance holes must be at least 4³/₄" in diameter

**Make Stronger,
More Uniform
Parts**

Rotary Resin
Shutoff Valve
**100%
STOPS Drool!**

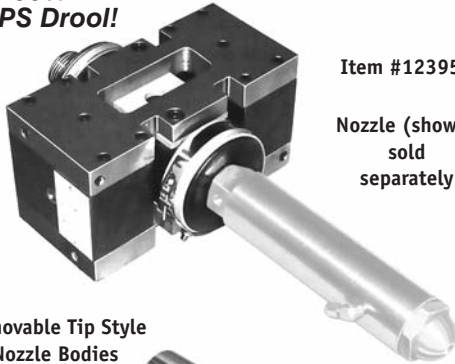

Item #123957
Nozzle (shown)
sold
separately

Removable Tip Style
Nozzle Bodies
with Gas Port



Item
#123964

Add-On,
Self-Actuating
Shutoff
with Gas Port



Item
#126847

Add-On
Gas Port



Item
#123925

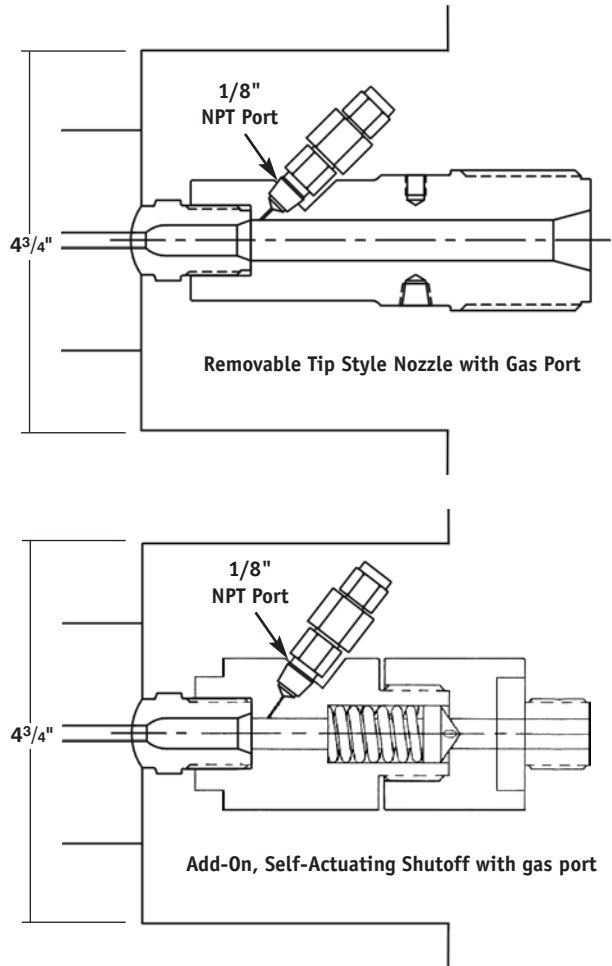

Custom Threads Available



www.imscompany.com

phone order toll-free
(USA & Canada)

1.800.537.5375

fax order toll-free (USA & Canada)

phone order toll-free (Mexico)

tech support toll-free (USA & Canada)

e-mail

1.888.288.6900

001.888.304.1307

1.866.467.9001

sales@imscompany.com



Specifications and Prices

Rotary Resin Shutoff Valve

- Stainless steel

Operating Temperature: 550° F to 600° F
Hydraulic Pressure: 500 psi max.
Nozzle Thread: female 1³/₄"-8
Barrel Thread: male 1³/₄"-8
Rear Opening: 1" dia., 60° angle
Hose Fitting: 1/8"-27 N.P.T.
Dimensions: 7⁵/₈" l x 9" w x 4³/₄" h

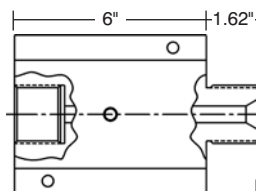

Patent #5,494,254

Requires only two hydraulic hoses, four 3/8" dia. x 5 1/2" long heater rods and a source of hydraulic power able to deliver 500 psi max. at 3 gpm with a simple 3-way spring return valve

123957	Rotary Resin Shutoff Valve (with gas port)	\$6,447.00
132581	Rotary Resin Shutoff Valve (without gas port)	6,729.00

Removable Tip Style Nozzle Bodies with Gas Port

- For use with Rotary Resin Shutoff Valve
- 4140 heat treated steel

Tip Thread: female 7/8"-14

Removable Tip Style Nozzle Bodies with Gas Port for use with Rotary Resin Shutoff Valve Complete with 1³/₄"-8 male thread, 3/4" rear opening and 1/4"-28 and 1/8" N.P.T. T/C holes

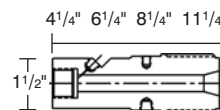

Patent #5,149,546

123964	(5" overall length with tip)	\$546.25
123895	(7" overall length with tip)	573.55
123896	(9" overall length with tip)	546.35
123897	(12" overall length with tip)	710.20

Add-On, Self-Actuating Shutoff with Gas Port

- Works with gas assist pressures up to 8500 psi
- Also useable for conventional molding

Tip Thread: female 7/8"-14

Nozzle Thread: male 7/8"-14

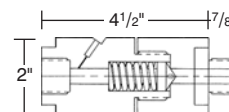

Patent #5,149,546

126847	Add-On, Self-Actuating Shutoff with Gas Port and 1/4"-28 T/C hole	\$2392.95
137165	Barrel Add-On, Self-Actuating Shutoff with Gas Port Tip Thread: female 7/8"-14 Barrel Thread: male 1 ³ / ₄ "-8	2502.25

Add-On Gas Port

- For use with any standard nozzle and tip
- 4140 heat treated steel

Tip Thread: female 7/8"-14

Nozzle Thread: male 7/8"-14

Rear Opening: 1/2" dia.

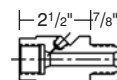

Patent #5,149,546

123925	Add-On Gas Port for use with any standard nozzle tip (shutoff required)	\$464.30
--------	---	----------

Check Valves

- Cone (needle) and spring loaded styles
- Fittings included

Patent #5,149,564

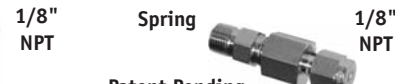

Patent Pending

123927	Check Valves with Fittings — Stainless steel cone (needle) style	\$109.20
126733	Check Valves with Fittings — Stainless steel spring loaded style	273.05

In-Mold Gas Pins

In-Mold Gas Pins



Patent #RE35-705

Available

Ask about other sizes and threads

Spare Part

130564	Replacement internal spring for Item #126847	\$ 70.90
131846	Replacement internal cone for Item #126847	198.95
130634	Replacement internal spring for Item #126733	58.55



www.imscompany.com | phone order toll-free (USA & Canada) **1.800.537.5375**

fax order toll-free (USA & Canada) | phone order toll-free (Mexico) | tech support toll-free (USA & Canada) | e-mail
1.888.288.6900 | **001.888.304.1307** | **1.866.467.9001** | **sales@imscompany.com**

