



IMS SPIRAL™ -Curve Replacement Hoppers

Feed material at a remarkably consistent rate

A press needs consistent, smooth intake from its hopper to assure quality products. Traditional tapered hoppers can feed material into the screw in surges, resulting in voids and clumps. But the IMS SPIRAL™ -Curve Hopper makes smooth intake possible. Recognizing this, some press manufacturers install IMS SPIRAL hoppers as original equipment.

The IMS SPIRAL™ -Curve Hopper uses a natural logarithmic curve to feed material at a remarkably consistent rate. No bridging or surging occurs. Whether full or nearly empty, the SPIRAL™ -Curve Hopper steadily feeds any type or shape of material, including virgin or mixed material. The screw flights are consistently full. Your process becomes more predictable and repeatable, improving part quality.

- Logarithmic SPIRAL™ -Curve design makes the flow of material more efficient, eliminating bridging
- Minimizes part rejects
- Retrofits any existing press
- Heavy duty mounting flange customized to your press



Especially helpful when molding with regrind

Lid and custom flange not shown

- Stainless steel construction
- Stainless steel lid
- Optional sight glass/drain shows material level
- Optional hopper extensions increase capacity up to nearly 400%

See Ordering Information on Pages 690-693



Standard, 60° Taper Replacement Hoppers

For ALL makes and models of injection molding machines

Excellent for free-flowing virgin material

Stainless Steel ensures durability and corrosion resistance

IMS Standard, 60° Taper Hoppers are specially designed to replace OEM components. Thanks to our variety of sizes and economical, add-on extensions, IMS can provide exceptional quality hoppers at very affordable prices.

- High quality Type-304 stainless steel — suitable for food grade applications
- Heavy duty mounting flange made to order
- Optional sight glass/drain permits viewing level of material
- Optional clamp-on extensions expand capacity (24" Dia. ONLY)

PRICE INCLUDES Lids and custom mounting flanges (not shown)

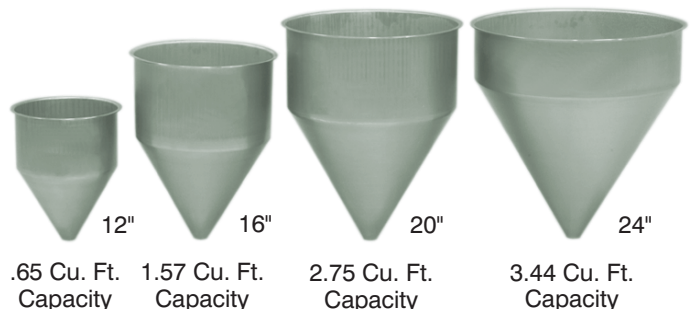

See Ordering Information on Pages 690-693

SPIRAL™ is a trademark of IMS Company



www.imscompany.com |

phone order toll-free (USA & Canada) 1.800.537.5375

fax order toll-free (USA & Canada) 1.888.288.6900

phone order toll-free (Mexico) 001.888.304.1307

tech support toll-free (USA & Canada) 1.866.467.9001

e-mail

sales@imscompany.com



IMS Replacement Feed Hoppers

Choose the style best suited for your material

A molding machine needs consistent, smooth intake from its hopper to assure quality products. Depending on the material being used, traditional tapered hoppers can feed material into the screw in surges, with voids and clumps. But the IMS SPIRAL™-Curve Hopper makes smooth intake possible.

IMS standard 60° Taper Hoppers are designed to replace originally purchased equipment. A variety of sizes and extensions let you buy just the right equipment for your shop at an affordable price. The OEM Replacement Hopper from IMS is well suited for virgin material. For materials with difficult flow characteristics, select our SPIRAL™-Curve Replacement Hoppers.

The IMS SPIRAL™-Curve Hopper uses a natural logarithmic curve to feed material at a remarkably consistent rate. No bridging or surging occurs. Whether full or nearly empty, the SPIRAL™-Curve Hopper steadily feeds any type or shape of material, including coarse or mixed material. The screw flights are consistently full. Your process becomes more predictable and repeatable, improving part quality.

Standard 60° Taper Hopper

Works best with free-flowing virgin material.

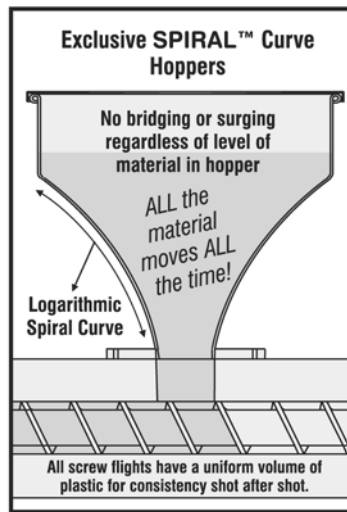
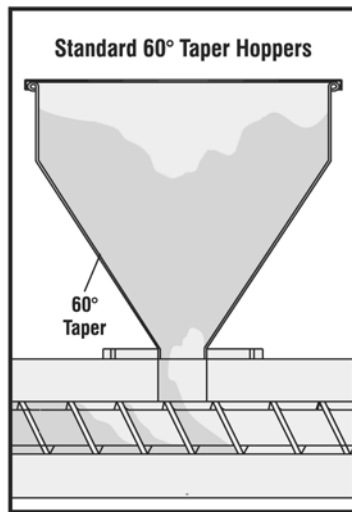

Exclusive SPIRAL™-Curve Hopper

Ideal for coarse or mixed material

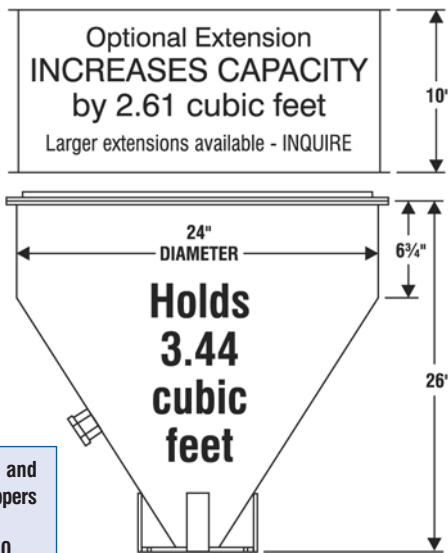

NOTE: 12", 16" and 20" diameter hoppers also available See Page 690

NOTE: Where tramp metal protection is necessary, use only drawer-type magnets so as not to interrupt flow pattern in hopper.

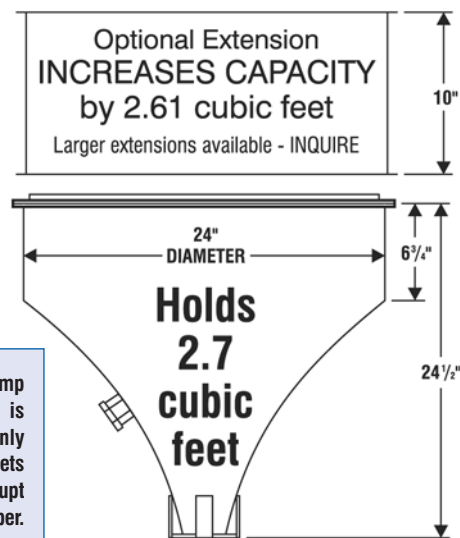

www.imscompany.com | phone order toll-free (USA & Canada) **1.800.537.5375**

fax order toll-free (USA & Canada) 1.888.288.6900 | phone order toll-free (Mexico) 001.888.304.1307 | tech support toll-free (USA & Canada) 1.866.467.9001 | e-mail sales@imscompany.com



Build Your Own Hopper

Customize your Hopper with all of the available accessories from IMS. Select from a wide variety of options - Flanges, Slide Gates, Sight Glasses, Lids, Extensions, and Drying packages - so that you have the exact hopper you need for your operation. Some of the options are pre-assembled and ready to ship today, while others are available with a short lead time.

Hopper Only				
Style	Diameter			
	12"	16"	20"	24"
Conical	120274	120283	120252	120208
Spiral	N/A	N/A	N/A	112134

Hopper with Blank Flange					
Style	Feed Throat Size	Diameter			
		12"	16"	20"	24"
Conical	2"	145043	143349	RFQ*	RFQ*
	2-1/2"	RFQ*	143350	RFQ*	RFQ*
	3"	RFQ*	143351	RFQ*	143423
	4"	RFQ*	RFQ*	RFQ*	143424
OR					
Hopper with Custom Flange					
Style	Feed Throat Size	Diameter			
		12"	16"	20"	24"
Conical	Specify**	143353	143354	143355	143356
Spiral	Specify**	N/A	N/A	N/A	143357

*RFQ=Request for Quote
 ** See form on page 693

Add a Slide Gate Up to 8" x 8"				
Diameter				
12"	16"	20"	24"	
143111				

Add A Sight Glass 2" x 4" Clear Poly				OR	Add A Sight Glass & Drain			
Diameter					Diameter			
12"	16"	20"	24"		12"	16"	20"	24"
143338				143352				



11



www.imscompany.com | phone order toll-free (USA & Canada) 1.800.537.5375

fax order toll-free (USA & Canada) 1.888.288.6900 | phone order toll-free (Mexico) 001.888.304.1307 | tech support toll-free (USA & Canada) 1.866.467.9001 | e-mail sales@imscompany.com



Choose a Lid				
Description	Diameter			
	12"	16"	20"	24"
Standard Lid	120284	120280	120251	120207
Hopper Lid: handle, hanging hook, clamping flange	N/A	N/A	N/A	112131
Hopper Lid: hanging hook, clamping flange, plus cut out to mount loader	N/A	N/A	N/A	143110



Add an Extension for More Capacity		
Description	Size	Item #
Cylinder Only	10"	112127
Extension Kit		121868
Drying Extension Cylinder Only		113157
Drying Extension Kit		114318
Cylinder Only	20"	125295
Extension Kit		126124
Replacement Parts		
Description	Size	Item #
Band Clamp	24"	112139
Gasket	24"	112136



Hopper with Drying Kit		
Style	Description	Item #
Conical	Complete Kit Includes: stainless steel hopper, lid, drying extension, 2 clamp rings, 2 gaskets, dispersion cone, inlet elbow, exhaust pipe and custom flange under 8" x 8"	121872
Spiral		121858



continued on next page



www.imscompany.com | phone order toll-free (USA & Canada) 1.800.537.5375

fax order toll-free (USA & Canada) 1.888.288.6900 | phone order toll-free (Mexico) 001.888.304.1307 | tech support toll-free (USA & Canada) 1.866.467.9001 | e-mail sales@imscompany.com

