

Sorts Parts & Runners with as little as .015" different in size

★ **Simple Two-Knob Roller Adjustment**
lets you set the **PRECISE** gap needed to suit your parts and runners

USE WITH ANY CONVEYOR UP TO 18" WIDE

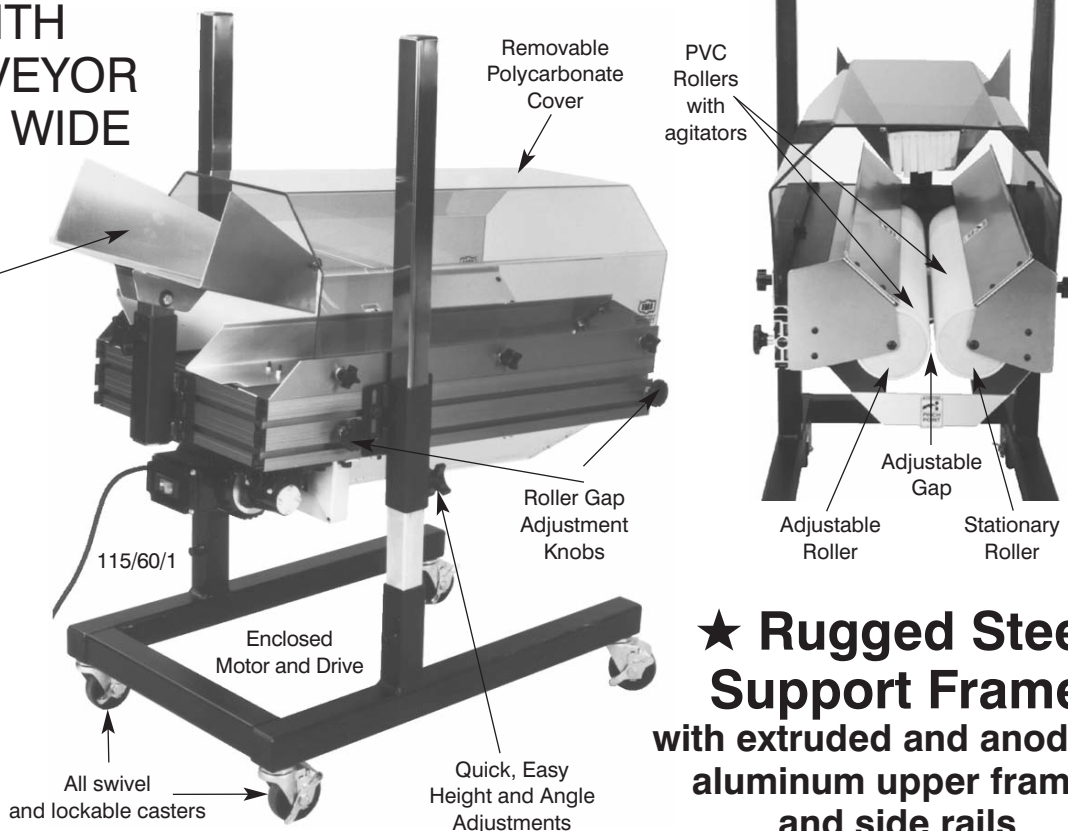

Ideal for Sorting Parts with Minimal Size Difference

Send us a box of your parts and runners for a free automation evaluation and quote. Please call for an RA number before shipping.

★ **Rugged Steel Support Frame** with extruded and anodized aluminum upper frame, and side rails

SPECIFICATIONS

- Part Drop Gap Width 0-1"
- Drive Motor 1/15 hp, gearmotor with 7 ft grounded power cord
- Dimensions 34" long x 20" wide x 36" to 48" infeed height
- Shipping Weight 225 lbs.

HERE'S HOW IT WORKS

Adjust trough between counter-rotating rollers so smaller pieces drop through but larger pieces do not. Feed parts into infeed chute. Smaller pieces drop through rollers into conveyor or box underneath separator; larger pieces slide down the trough and drop off the end of separator into another box or conveyor. Agitators on rollers help to untangle parts, to improve sorting accuracy.

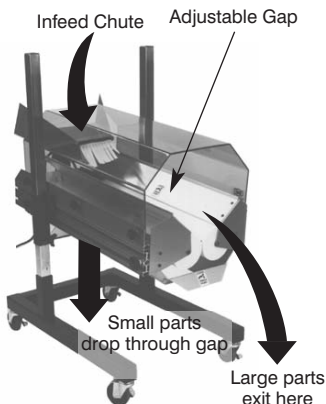

PRICE COMPLETE as shown
Item No. 116285

\$3,328 ea.