



IMS Select

# Goblin SHARXX Economy Low Speed/Robot Feed Beside-the-Press Plastic Granulators

For sprues/runners, small to medium parts and film



**Light & Medium Duty**

### 3 Blade, Staggered Rotor Design

with more cuts per revolution, results in higher throughput. Smaller bites reduce the chance of jamming or shearing. Cutting is cleaner, quieter and uses less energy.

**Scissor-cutting action** from the slanted cassette rotor knives results in superior quality regrind.

**Tangential feed** allows the granulator to handle parts as well as runners.

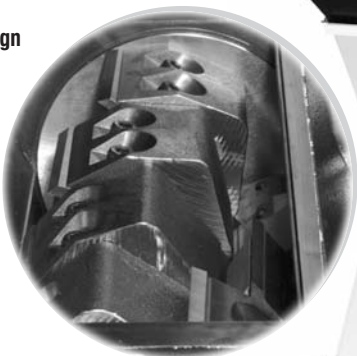

**Oversized bearings** handle heavier shock loads without bearing wear, reducing the chances of bearing failure.



### Reversible Screen

provides even wear to extend the life of the screen.



**Drop-down screen** cradle for fast cleanout in response to a change in plastic type and/or color. Provides easy access to the cutting chamber for cleaning and service.



Unique D2 tool steel **cassette knives** are economical and may be readily replaced when worn. The elimination of costly and time-consuming knife resharping saves money and increases granulator up-time.



### Robot and Hand Feed Hopper



**Removable flaps** provide convenient cleaning

**Multiple safety interlocks** prevent injury by denying access to the granulator while operating.

**Gas cylinder assisted hopper**

**Allen-Bradley Starters (110 V)**

No knife adjustment required

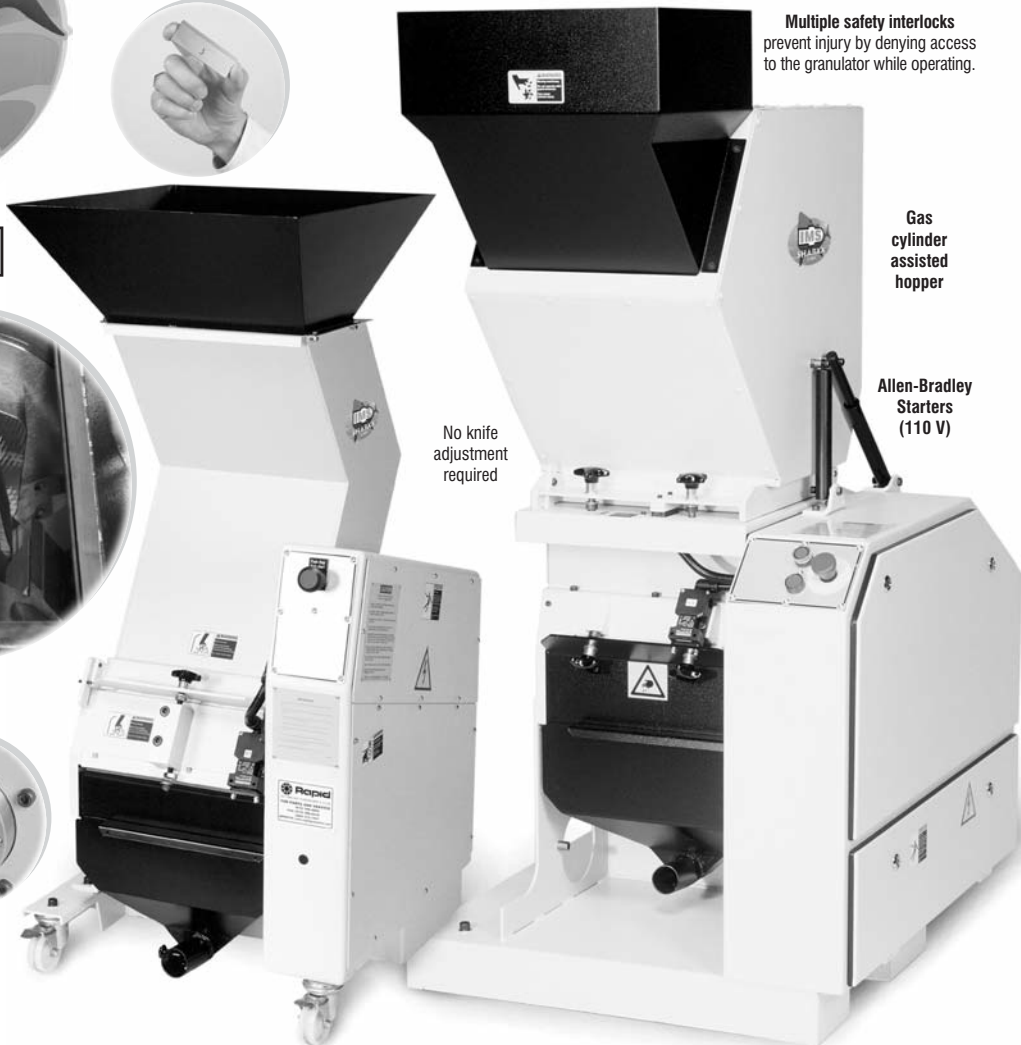

**Vacuum Take-Off Tube**  
(1 1/2" - 2 1/2" O.D.)

**Solid rotor pulley** adds inertia to the rotor to provide more cutting power while utilizing less horsepower.



Compact and mobile, **caster-mounted base** saves valuable floor space and provides greater versatility. Casters can be locked once granulator is in place.

IMS SHARXX LINE™ is a trademark of IMS Company



[www.imscompany.com](http://www.imscompany.com) | phone order toll-free (USA & Canada) **1.800.537.5375**

fax order toll-free (USA & Canada) | phone order toll-free (Mexico) | tech support toll-free (USA & Canada) | e-mail  
**1.888.288.6900** | **001.888.304.1307** | **1.866.467.9001** | [sales@imscompany.com](mailto:sales@imscompany.com)



# Goblin SHARXX — SPECIFICATIONS

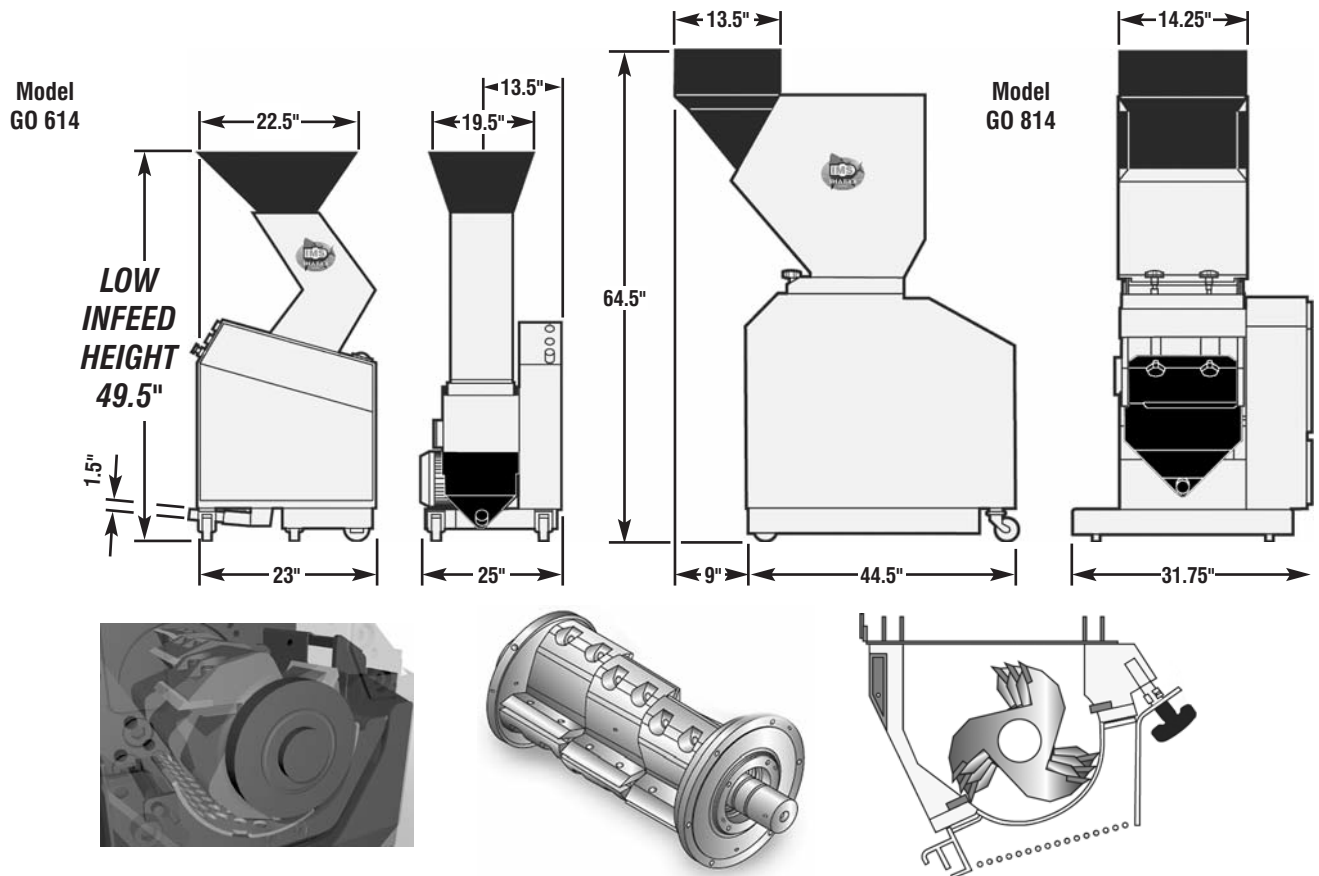

## IMS GOBLIN SHARXX

### STANDARD UNIT FEATURES INCLUDE:

- Robot and Hand Feed Hopper
- 3 Blade, Staggered Rotor Design
- TEFC 3HP (GO614) or 7.5HP (GO814) Motor (230/460 volt)
- Reversible Screen
- Vacuum Take-Off Tube (1 1/2" -2 1/2" O.D.)

Model	Throughput	Cutting Chamber	Base Price
GO 614	0-120 lb/hr	6" x 14"	\$6,750
GO 814	0-190 lb/hr	8" x 14"	8,030

**Model GO 614 SPECIFY:** 1/8", 3/16", 1/4" or 5/16" Screen

**Model GO 814 SPECIFY:** 1/4", 5/16", 3/8" or 1/2" Screen

**and Voltage**

#### NOTE

IMS GOBLIN SHARXX™ have no options other than voltage  
Design/appearance subject to change without notice

### — OPTIONS (Inquire for prices) —

	GO 614	GO 814
<b>ROTORS</b>		
3 Blade, Staggered Rotor	Std.	Std.
<b>MOTORS</b>		
3 HP	Std.	—
7.5 HP	—	Std.
<b>CONTROLS</b>		
230 or 460 Voltage	Std.	Std.
208 or 575 Voltage	Inq.	Inq.*
<b>HOPPERS</b>		
Robot / Hand Feed	Std.	Std.
<b>UNLOADING</b>		
Vacuum Take-Off Tube (1.5"-2.5" O.D.)	Std.	Std.

\*Not 208 Voltage



Designed for easy access to all components. Both the hopper and screen cradle pivot away from the rotor, providing simple access for routine **easy cleaning and maintenance.**

**Model GO 614**



[www.imscompany.com](http://www.imscompany.com)

phone order toll-free (USA & Canada)

**1.800.537.5375**

fax order toll-free (USA & Canada)

phone order toll-free (Mexico)

tech support toll-free (USA & Canada)

e-mail

**1.888.288.6900**

**001.888.304.1307**

**1.866.467.9001**

**sales@imscompany.com**

