

Custom Mold Side Curtains

3

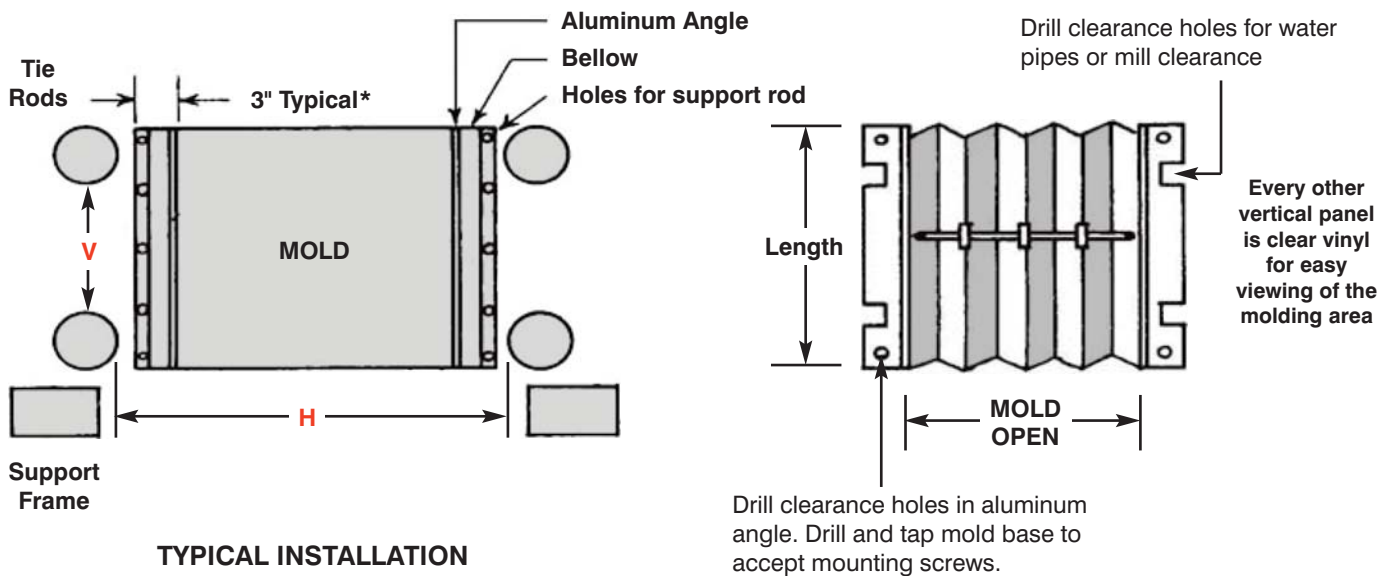

***Note:**
 Side curtains require 3" gap between mold and tie bar. The curtain can only be as long as the tie bar spacing if adequate space does not exist.
 Ensure adequate clearance between waterline fittings on the parting line, to allow the curtain to collapse in between when the mold is closed.
 Curtain open stroke and curtain length should not exceed 36".

1. (H) Distance between Tie Rods: _____ (V) Distance between Tie Rods: _____
2. Distance between Mold: (Horizontal) _____ Distance between Mold:(Vertical) _____
3. Mold Open: _____
4. Curtain Length: _____

Date: _____ Quantity: _____ Phone: (_____) _____ Fax: (_____) _____

Name: _____ Title: _____

Company Name: _____ Email: _____

Address: _____

City: _____ State: _____ Zip: _____



www.imscompany.com | phone order toll-free (USA & Canada) **1.800.537.5375**
 fax order toll-free (USA & Canada) | phone order toll-free (Mexico) | tech support toll-free (USA & Canada) | e-mail
1.888.288.6900 | **001.888.304.1307** | **1.866.467.9001** | sales@imscompany.com

