

Drawer Magnet Housing Flange/Accessory Form

SPECIFY:

See next page for optional Isometric View

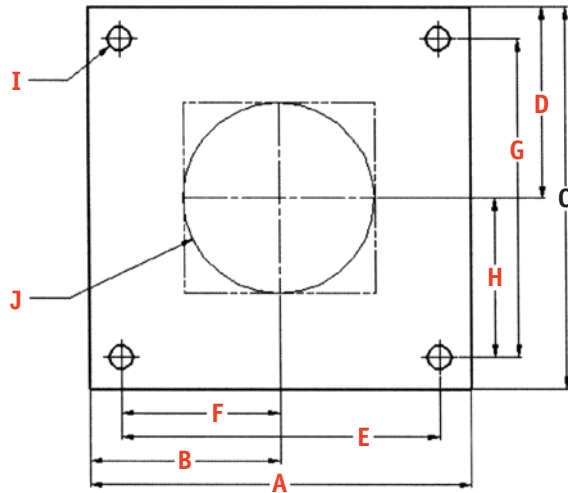

**Bottom Flange
Operator Side (Front)**

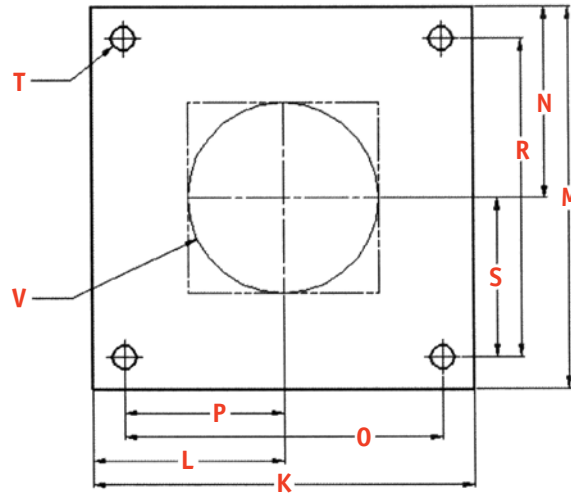

**Top Flange
Operator Side (Front)**

A _____ **H** _____
B _____ **I** _____ (bolt size used)
C _____ **J** — **Opening**
 Round _____
 Square _____
 Rectangle _____
G _____ Front to Back _____
 Side to Side _____

K _____ **S** _____
L _____ **T*** _____ Threaded Holes
 (thread size used) Studs
M _____
N _____ **V** — **Opening**
 Round _____
 Square _____
 Rectangle _____
O _____ Front to Back _____
P _____ Side to Side _____
R _____

*Studs will be required if bolt pattern falls on housing body

Make of Press: _____ Serial Number: _____

Model: _____ Screw Size: _____ Ounce: _____

Make of Hopper: _____ Hopper Capacity: _____ lbs.

Optional Equipment:

Slidegate Shut-off With Discharge Dump Tube: Rear Other _____
 Tapped Hole for Liquid Dispensing System With Purge Hopper: R.H. Side L.H. Side
 Other _____

Date: _____ Quantity: _____ Phone: (_____) _____ Fax: (_____) _____

Name: _____ Title: _____

Company Name: _____ Email: _____

Address: _____

City: _____ State: _____ Zip: _____



www.imscompany.com | phone order toll-free (USA & Canada) **1.800.537.5375**

fax order toll-free (USA & Canada) | phone order toll-free (Mexico) | tech support toll-free (USA & Canada) | e-mail
1.888.288.6900 | **001.888.304.1307** | **1.866.467.9001** | sales@imscompany.com



Isometric View of Flange Dimensions

3

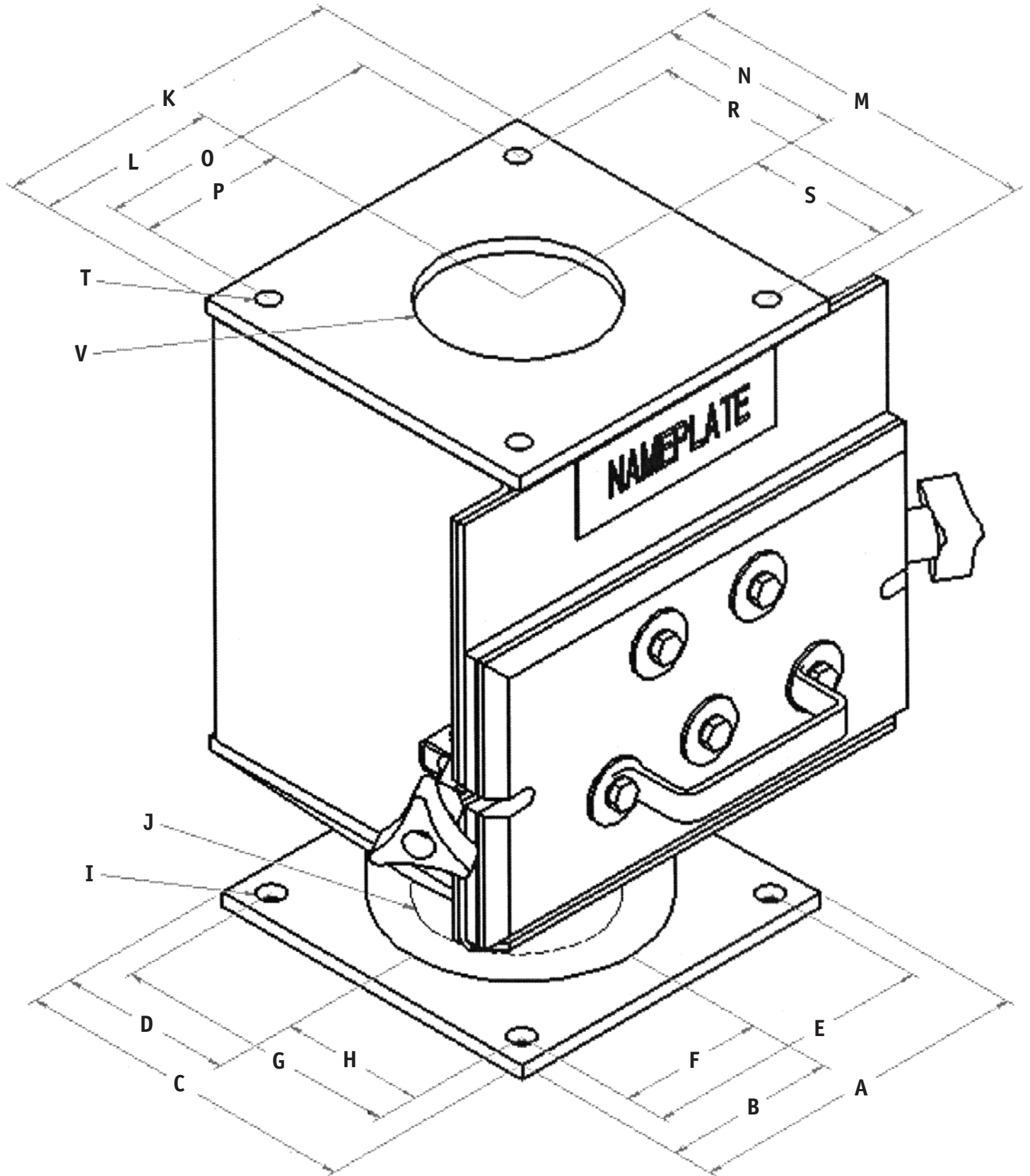

www.imscompany.com | phone order toll-free (USA & Canada) **1.800.537.5375**

fax order toll-free (USA & Canada) | phone order toll-free (Mexico) | tech support toll-free (USA & Canada) | e-mail
1.888.288.6900 | **001.888.304.1307** | **1.866.467.9001** | sales@imscompany.com

