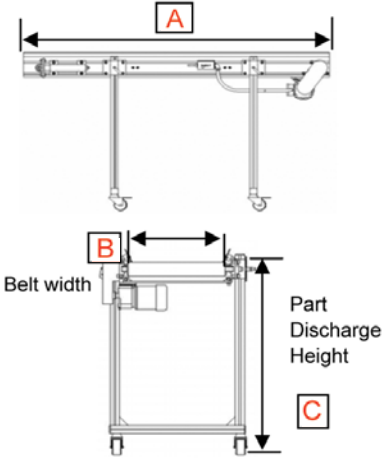
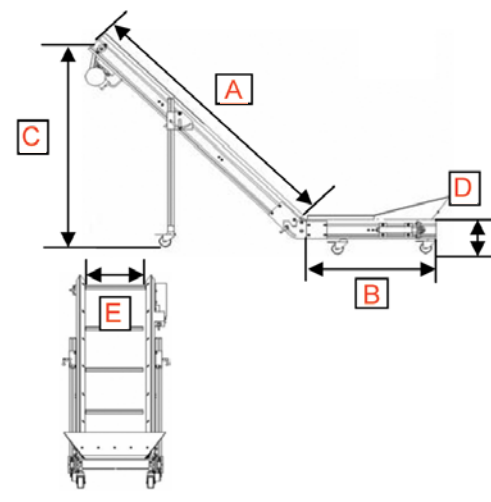
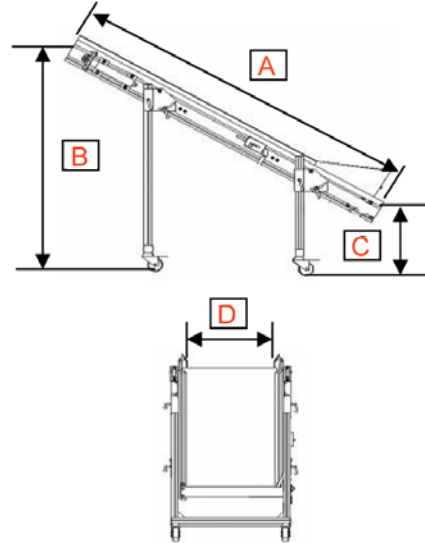

IMS Custom Conveyors

Select type :

<p>Horizontal <input type="checkbox"/></p> <p>Style: Flat top <input type="checkbox"/> (select one) 3" Std side rails <input type="checkbox"/> Other (specify) <input type="checkbox"/></p>  <p>Overall Length (A) _____ Belt Width (B) _____ Height (C) _____</p>	<p>Horizontal to Incline <input type="checkbox"/></p>  <p>Incline Length (A) _____ Horizontal Length (B) _____ Discharge Height (C) _____ Infeed Height (D) _____ Belt Width (E) _____</p>	<p>Incline <input type="checkbox"/></p>  <p>Overall Length (A) _____ Discharge Height (B) _____ Infeed Height (C) _____ Belt Width (D) _____</p>
---	---	---

Belt - (Standard Aligator Lacing)
 Optional - Seamless Belt
 Select one :
 Color Black
 White
 Other color specify : _____
 Temperature / Type of Material Conveyed : _____

Cleats - Yes No
 Std Cleat Height is 1.5" : other _____
 Cleats spacing 18" Standard
 Other than standard -
 Cleat spacing required : _____

Note:
 If overall width of conveyor is critical, please specify max width dimension:

Motor - (check one) Std - 19 fpm
 Variable speed - 0-27.5 fpm
 Other -

Options - (check one or more) Indexing
 Reversing
 Heavy Duty Slider Bed (to withstand heavier part loads over 60# per sq foot)

Part deflector at discharge end
 Photoelectric eye

Motor Position -

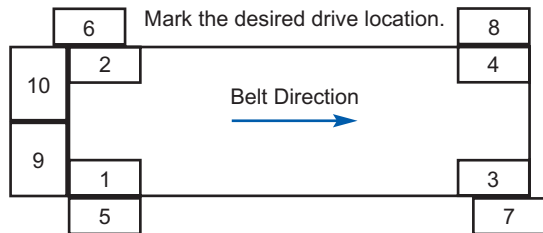

- 1, 2, 3, 4 - Mounted underneath. (standard)
- 5, 6, 7, 8 - Mounted on side. (up-charge)
- 9, 10 - Mounted on end. (up-charge)

Injection Machine -

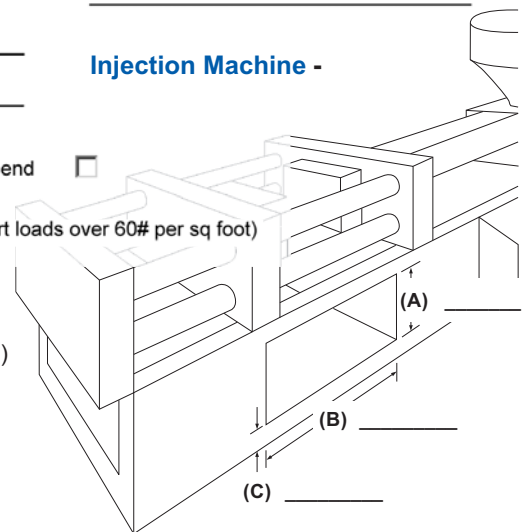

Date: _____ Quantity: _____ Phone: (_____) _____ Fax: (_____) _____
 Name: _____ Title: _____
 Company Name: _____ Email: _____
 Address: _____
 City: _____ State: _____ Zip: _____